

KW-FMP2-A/B[A:AC , B:Battery] FOR BULB,ANGLE,I&T-BAR

FILLET & BUTT WELDER FOR BULB FLATS, TOP TRAVEL, 2TORCH, STITCH & CONTINUOUS
BULB FLAT SIZE, 80-310mmH

APPEARANCE

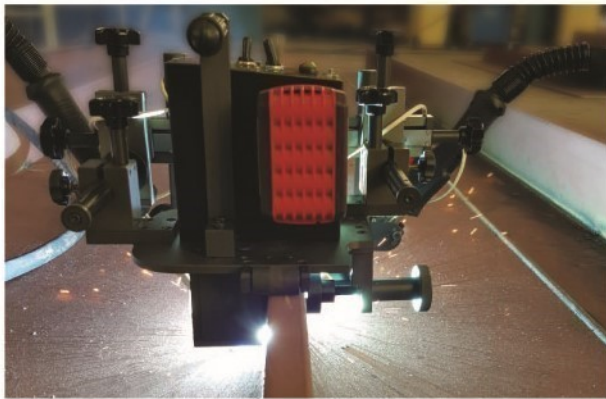

FEATURES

- Two torch, Applying various profiles as below
- Torch holder angle widely
- Both mechanized & manual torches useful.
- Max pulling power 30kgf and Max. 30 degree climbable.
- Crate filling time at the beginning and ending of the welding can be controlled for 0~3 seconds.
- Travel speed in cm/min or inch/min programmable.
- Battery power, 18Vdc 6.0Ah lithium-ion, 10-12Hrs use

FILLET WELDING

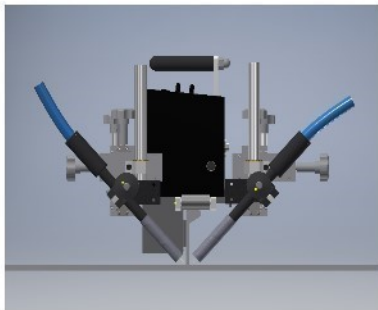

BUTT WELDING

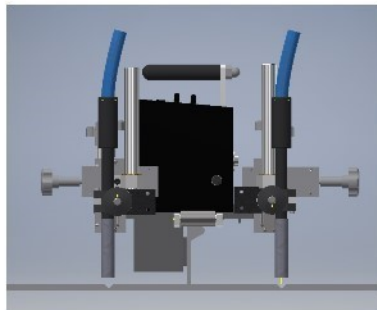

WORK PIECE

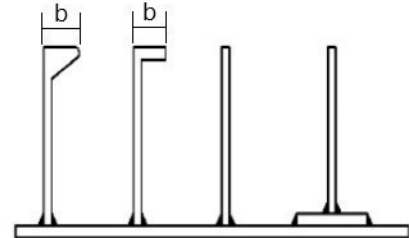

Height range : 80~310mm
B range : 6~100mm

MAJOR PARTS	DESCRIPTIONS	SPECIFICATIONS
General	Size in mm(WHL), Weight	Carriage: 500 x 360 x 350, 9.0Kg
	Input Power	AC 100-240V, 50-60Hz, 1 Phase
		Lithium-ion Battery 18Vdc 6.0Ah 10-12Hrs use
Traveling Unit	Motor	24Vdc, 10W, 5,000rpm
	Reducer	1:624
	Speed	0~860mm/min
	Power transmission	4 wheels chain driven
	Affixing	Natural
X-Y slide	X-slide stroke	0~60mm
	Y-slide stroke	0~150mm
	Z-slide stroke	0~120mm