

KW-MR4[AC]

MULTI-POSITION FUEL-GAS CUTTER & WELDER

APPEARANCE

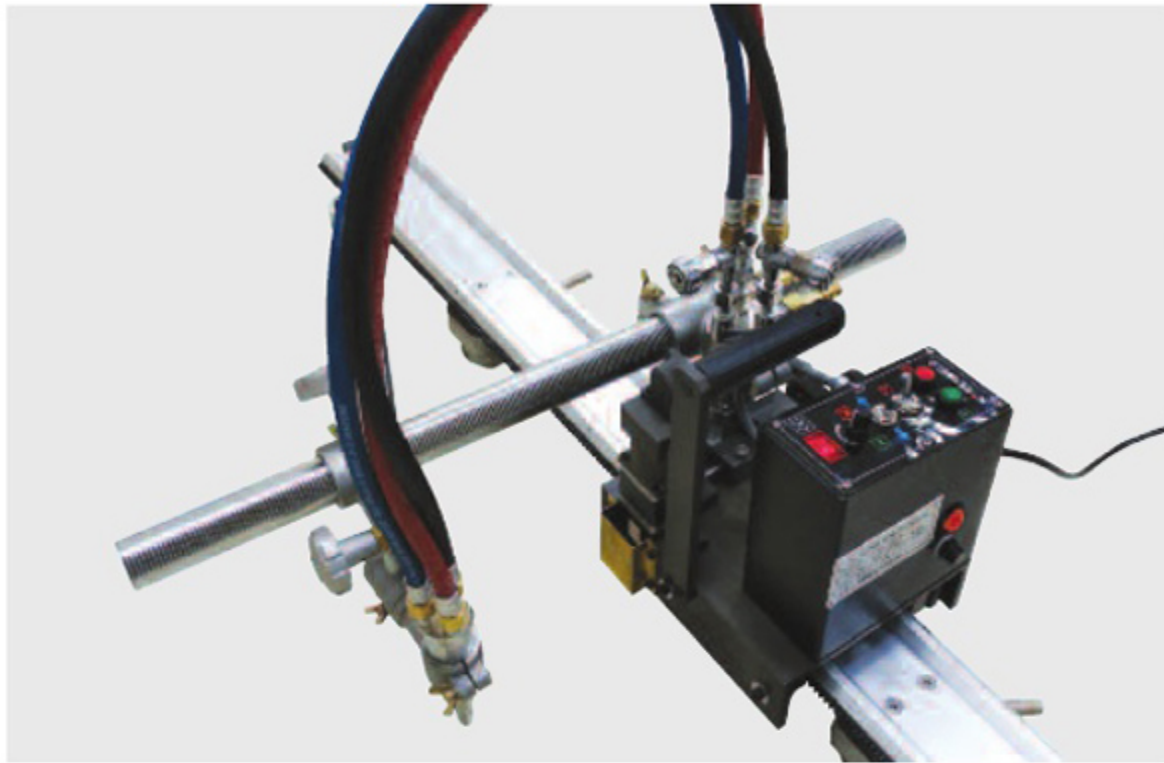

FEATURES

- Stable driving system enables to get high cutting quality.
- Torch is changeable for cutting and welding(option)
- High speed traveling of Max. 2,000mm/min.
- Display window indicating actual travel speed as set value.
- When changing welding torch & clamp, the carriage able to use welding
- Applicable to multi-position for gas cutting.

MOUNT & CUTTING

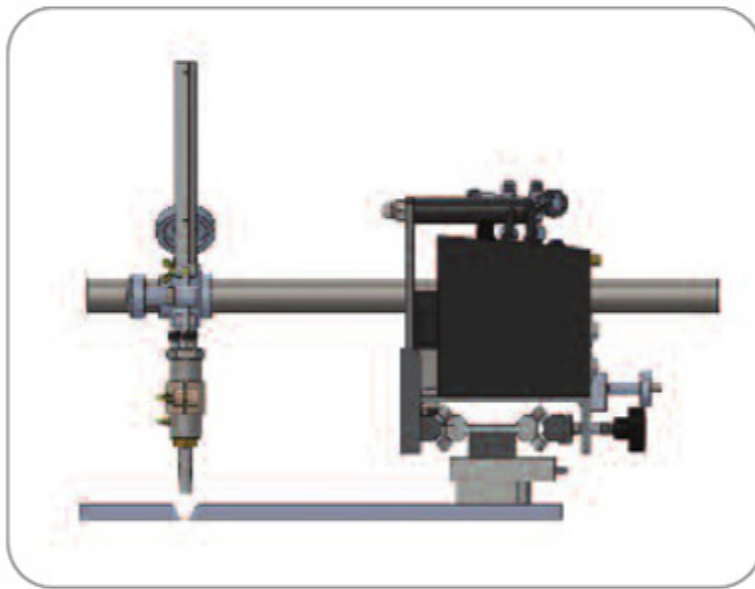

WELDING

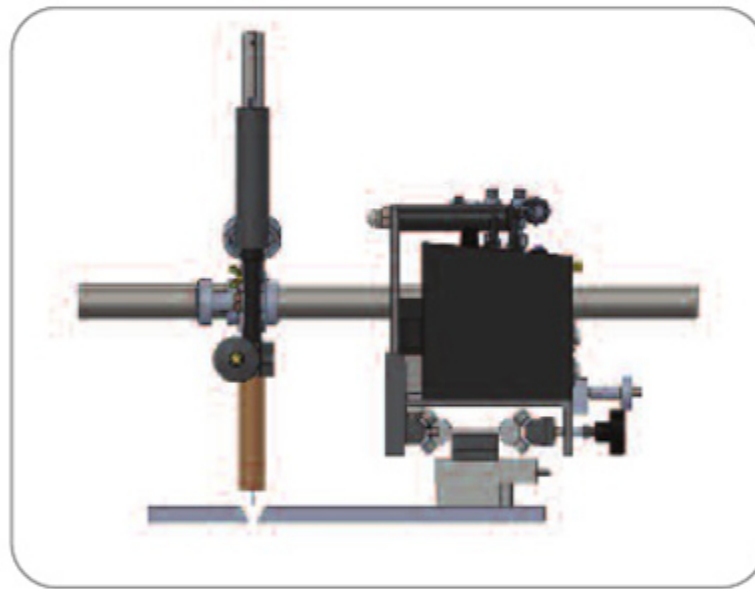

FLEXIBLE RAIL

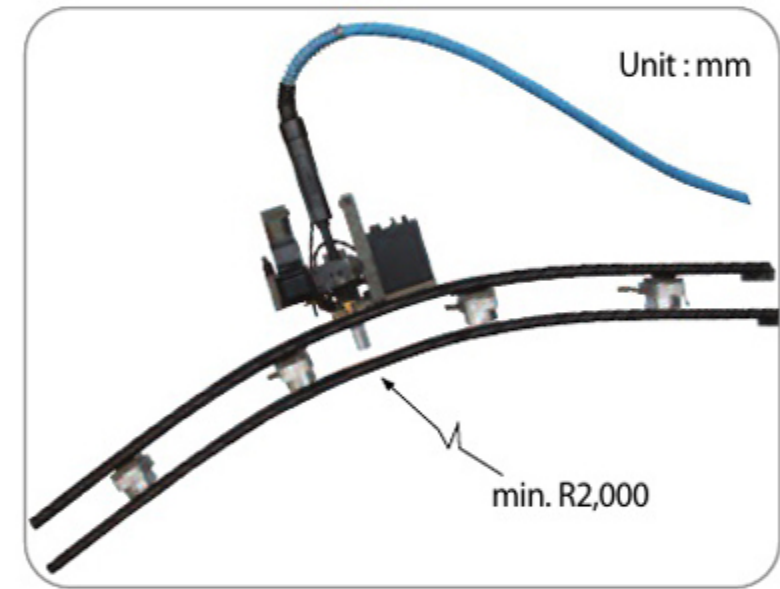

| MAJOR PARTS | DESCRIPTIONS | SPECIFICATIONS |
|--|--------------------------------|------------------------------------|
| General | Size in mm(WHL), Weight | Carriage: 270 x 600 x 400, 9.0Kg |
| | Input source | AC 100-240V, 50-60Hz, 1 Phase |
| Traveling unit | Motor | 24Vdc, 10W, 5,000rpm |
| | Reducer | 1:144 (PINION P.C.D Ø21) |
| | Speed | 2,000mm/min |
| | Power transmission | Rack & Pinion, Geared motor driven |
| | Gear Clutch | Manual moving clutch |
| X-Y slider | X-slide stroke | 0~500mm |
| | Y-slide stroke | 0~200mm |
| Rails, 1.5M/pc Extendable. See the rail list | Rigid aluminum magnet rail | RR3M |
| | Rigid aluminum vacuum rail | RR3V |
| | Flexible stainless magnet rail | RF4M |
| | Flexible stainless vacuum rail | RF5V |
| Cutting Torch | Barrel Diameter | 30mm |