

# KW-FW1

## FILLET WELDER, WALL DRIVING, SINGLE TORCH, STITCH & CONTINUOUS



### FEATURES

- Single torch, Wall driving with the magnet fitted on the bottom of the carriage
- Stitch or continuous welding mode available
- X-Y slider helps setting torch widely and speedy
- Both mechanized & manual torches useful
- Max pulling power 20Kgf and max. 30 degree climbable
- Crate filling time at the beginning and ending of the welding can be controlled for 0~3 seconds
- Travel speed in CM/min. or Inch/min programmable

WALL DRIVING

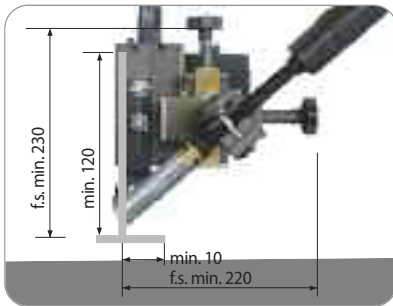

RADIUS

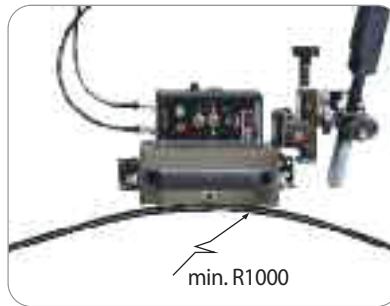

CLIMBALE PLANE

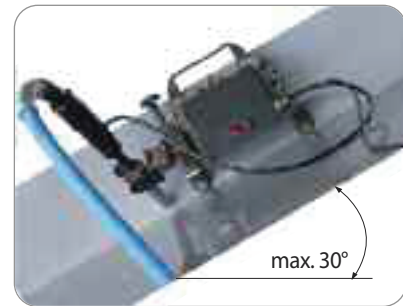

MAJOR PARTS	DESCRIPTIONS	SPECIFICATIONS
General	Size in mm(WLH) & Weight	Carriage: 380 x 215 x 230 mm, 6.0Kg Packing: 400 x 400 x 300, 10.0kg
	Input source	100~240Vac, 50~60Hz, 1 Phase
Traveling	Power unit	24Vdc 12W, 5000rpm
	Reducer	1:400(gear ratio1:1)
	Speed	0-1720mm/min
	Power transmission	4 wheels chain driven
	Magnet location	Bottom on the carriage
X-Y Slider	X slider stroke	0-50mm
	Y slider stroke	0-50mm