

## KW-FU2

FILLET-WELDER, U-RIB, STITCH & CONTINUOUS



### FEATURES

- Dual torches fillet welder for U-RIB profile
- Adjustable the height of carriage's ARM to the work piece.
- Both mechanized and manual torch can be applicable
- Other dimensions acceptable

### WORKPIECE DIMENSION

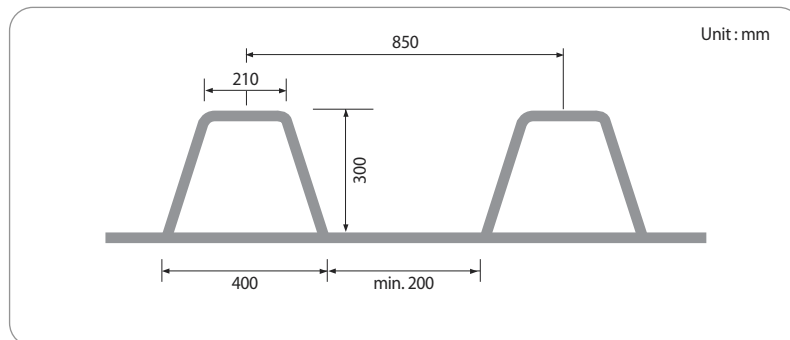

Other dimensions optioned

MAJOR PARTS	DESCRIPTIONS	SPECIFICATIONS
General	Size	750(w) x 270(L) x 650(H)
	Weight	12.5kg
	Input voltage	AC 100~204V, 50~60Hz, 1Phase
Travelling Unit	Mechanism	4Wheels-Chain-Drive
	Moter	DC24V, 12W, 5,000rpm
	Speed	0~860mm/min
	Reducer	1:400(GEAR RATIO 1:2)
XY Slider Unit	X slider stroke	0~50mm
	Y slider stroke	0~50mm