

# KW-FF2-A/B [A:AC ,B:Battery]

FILLET & BUTT WELDER, FLOOR TRAVEL, DUAL TORCH, STITCH & CONTINUOUS

## APPEARANCE

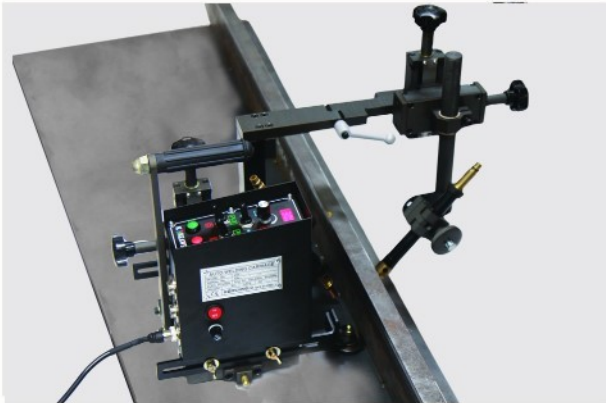

## FEATURES

- Dual torch, floor driving for Butt & Fillet welding.
- Stitch & continuous welding
- X-Y slider helps setting torch widely
- Both mechanized & manual torches useful.
- Max pulling power of magnet 20kgf and travels Max. 30° climbable.
- Limit switches stop the travel automatically.
- Crate filling time at the beginning and ending of the welding can be controlled for 0~3 seconds.
- Travel speed in cm/min or inch/min programmable.
- Battery power, 18Vdc 6.0Ah lithium-ion, 10-12Hrs use

BUTT WELDING

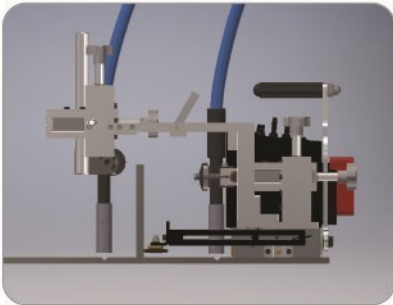

FILLET WELDING

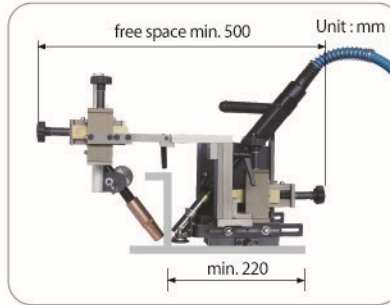

WORK PIECE

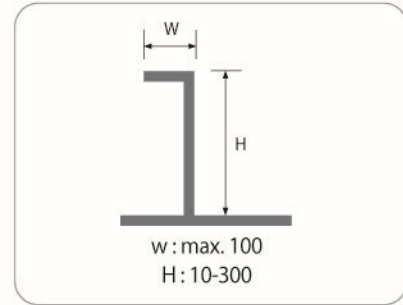

MAJOR PARTS	DESCRIPTIONS	SPECIFICATIONS
General	Size in mm(WHL), Weight	Carriage: 290 x 440 x 330, 9.0Kg
		Packing: 400 x 400 x 300, 14.0kg
	Input source	AC 100-240V, 50-60Hz, 1Phase
		Lithium-ion Battery 18Vdc 6.0Ah 10-12Hrs use
Traveling Unit	Power unit	24Vdc, 10W, 5,000rpm
	Reducer	1:624
	Speed	0~860mm/min
	Power transmission	4 wheels chain driven
	Magnet location	Bottom on the carriage
X-Y slide	X-slide stroke	0~50mm
	Y-slide stroke	0~50mm
Extended torch	Torch adjustable angle	0-90°
	X-slide stroke	0~50mm
	Y-slide stroke	0~50mm
	Y-clamp slide stroke	0~80mm